



Midway Metals

the stainless steel innovators

PRODUCTS & SERVICES CATALOGUE

PIPE PRODUCTS

9TH EDITION

SEAMLESS & WELDED PIPE

SPECIFICATIONS:	ASTM A312M-08	
LENGTHS:	6.1 METRE/RANDOMS	
FINISH:	WELDED SEAMLESS	ANNEALED & PICKLED COLD FINISH/HOT FINISH

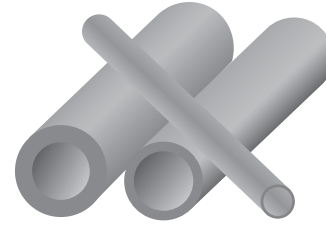

NB PIPE SIZE		SIZE		WELDED			SEAMLESS			APPROX. WGT
Inch	mm	O.D.	WT	304/L	316/L	2205	304/L	316/L	2205	kg/metre
SCHEDULE 10 / 10s										
1/8	6	10.287	1.244			☆	☆	☆		0.2772
1/4	8	13.716	1.651	★	★	☆	☆	☆	☆	0.4905
3/8	10	17.145	1.651	★	★	☆	☆	☆	☆	0.6301
1/2	15	21.336	2.108	★	★	☆	☆	☆	☆	0.9984
3/4	20	26.67	2.108	★	★	☆	☆	☆	☆	1.275
1	25	33.401	2.768	★	★	☆	☆	☆	☆	2.089
1 1/4	32	42.164	2.768	★	★	☆	☆	☆	☆	2.687
1 1/2	40	48.26	2.768	★	★	☆	☆	☆	☆	3.102
2	50	60.325	2.768	★	★	☆	☆	☆	☆	3.925
2 1/2	65	73.025	3.048	★	★	☆	☆	☆	☆	5.254
3	75	88.9	3.048	★	★	☆	☆	☆	☆	6.45
3 1/2	90	101.6	3.048	★	★	☆	☆	☆	☆	7.399
4	100	114.3	3.048	★	★	☆	☆	☆	☆	8.352
5	125	141.3	3.403	★	★	☆	☆	☆	☆	11.56
6	150	168.275	3.403	★	★	☆	☆	☆	☆	13.82
8	200	219.075	3.759	★	★	☆			☆	19.93
10	250	273.05	4.191	★	★	☆				27.82
12	300	323.85	4.572	★	★	☆				35.95
14	350	355.6	4.78	★	★	☆				42.1
16	400	406.4	4.78	★	★	☆				48.2
18	450	457.2	4.78	★	★					54.3
20	500	508	5.53	★	★					69.8
24	600	609.6	6.35	☆	★					96.2
SCHEDULE 40s / STD WALL										
1/8	6	10.287	1.727							0.3641
1/4	8	13.716	2.235	★	★		☆	☆		0.6321
3/8	10	17.145	2.311	★	★	☆	☆	☆		0.8445
1/2	15	21.336	2.768	★	★	☆	☆	★		1.266
3/4	20	26.67	2.87	★	★	☆	☆	★		1.682
1	25	33.401	3.378	★	★	☆	☆	★	☆	2.498
1 1/4	32	42.164	3.556	★	★	☆	☆	★	☆	3.382
1 1/2	40	48.26	3.683	★	★	☆	☆	★	☆	4.044
2	50	60.325	3.911	★	★	☆	☆	★	☆	5.435
2 1/2	65	73.025	5.156	★	★	☆	☆	★	☆	8.619
3	80	88.9	5.486	★	★	☆	☆	★	☆	11.27
3 1/2	90	101.6	5.74	★	★	☆	☆	★	☆	13.55
4	100	114.3	6.019	★	★	☆	☆	★	☆	16.05
5	125	141.3	6.553	★	★	☆	☆	☆	☆	21.75
6	150	168.275	7.112	★	★	☆	☆	★	☆	28.22
8	200	219.075	8.178	★	★	☆	☆	★	☆	42.48
10	250	273.05	9.271	★	★	☆				60.23
12	300	323.85	9.53	★	★	☆				73.88
14	350	355.6	9.53	☆	★	☆				81.2
16	400	406.4	9.53	☆	★					93.2
18	450	457.2	9.53	☆	☆					105.1
20	500	508	9.53	☆	★					117.0
24	600	609.6	9.53	☆	☆					140.8

SEAMLESS & WELDED PIPE

SPECIFICATIONS:	ASTM A312M-08	
LENGTHS:	6.1 METRE/RANDOMS	
FINISH:	WELDED SEAMLESS	ANNEALED & PICKLED COLD FINISH/HOT FINISH

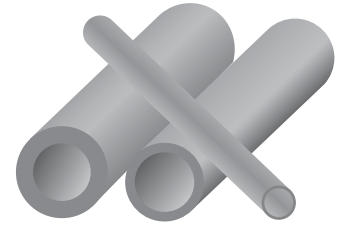

NB PIPE SIZE		SIZE		WELDED			SEAMLESS			APPROX. WGT
Inch	mm	O.D.	WT	304/L	316/L	2205	304/L	316/L	2205	kg/metre
SCHEDULE 80s / XS										
1/8	6	10.287	2.413					★		0.4679
1/4	8	13.716	3.023					★		0.7962
3/8	10	17.145	3.2					★		1.099
1/2	15	21.336	3.734				☆	★		1.618
3/4	20	26.67	3.911				☆	★	☆	2.193
1	25	33.401	4.546				☆	★	☆	3.231
1 1/4	32	42.164	4.851				☆	★	☆	4.459
1 1/2	40	48.26	5.08				☆	★	☆	5.402
2	50	60.325	5.537				★	★	☆	7.472
2 1/2	65	73.025	7.01				☆	★	☆	11.39
3	75	88.9	7.62				☆	★	☆	15.25
3 1/2	90	101.6	8.077				☆	★	☆	18.6
4	100	114.3	8.559				☆	★	☆	22.29
5	125	141.3	9.525				☆	★	☆	30.92
6	150	168.275	10.97				☆	★	☆	42.51
8	200	219.075	12.7				☆	★	☆	64.56
10	250	273.05	12.7					★		81.5
12	300	326.85	12.7							97.4
14	350	355.6	12.7							107.3
16	400	406.4	12.7							123.2
18	450	457.2	12.7							139.1
20	500	508	12.7							155.0
24	600	609.6	12.7							186.8
SCHEDULE 160										
1/2	15	21.336	4.75					☆		1.94
3/4	20	26.67	5.537					☆		2.882
1	25	33.401	6.35					☆		4.231
1 1/4	32	42.164	6.35					☆		5.602
1 1/2	40	48.26	7.137					☆		7.23
2	50	60.325	8.712					☆		11.07
2 1/2	65	73.025	9.525					☆		14.89
3	80	88.9	11.12					☆		21.3
4	100	114.3	13.48					☆		33.49
5	125	141.3	15.87					☆		49.04
6	150	168.275	18.23					☆		67.4
8	200	219.075	23.01					☆		111.1
10	250	273.05	28.57							172
12	300	326.85	33.32							238.5
14	350	355.6	35.71							281.3
16	400	406.4	40.46							364.7
18	450	457.2	45.23							459
20	500	508	50.01							563.9
24	600	609.6	59.51							806.3

NOMINAL WORKING PRESSURE

TECHNICAL DATA FOR 304L & 316L SEAMLESS PIPE

NOMINAL BORE SIZE	SCHEDULE 10s										SCHEDULE 40s										SCHEDULE 80s									
	TEMPERATURE °C										TEMPERATURE °C										TEMPERATURE °C									
	50	100	150	200	250	300	350	400	400	50	50	100	150	200	250	300	350	400	400	50	50	100	150	200	250	300	350	400	400	50
6	1/8	25.1	21.9	19	17.5	16.2	15.2	14.7	14.1	35	30.5	26.5	24.4	22.6	21.2	20.6	19.7	48.7	42.6	36.9	34	31.5	29.5	28.7	27.4					
8	1/4	25.1	21.9	19	17.5	16.2	15.2	14.8	14.1	34	29.8	25.8	23.7	22	20.6	20	19.2	45.9	40.1	34.7	32	29.7	27.8	27	25.8					
10	3/8	20.1	17.6	15.2	14	13	12.2	11.8	11.3	28.1	24.6	21.3	19.6	18.2	17	16.5	15.8	39	34.1	29.5	27.2	25.2	23.6	22.9	21.9					
15	1/2	20.6	18	15.6	14.4	13.3	12.5	12.1	11.6	27.1	23.7	20.5	18.9	17.5	16.4	15.9	15.2	36.5	31.9	27.6	25.4	23.6	22.1	21.5	20.5					
20	3/4	16.5	14.4	12.4	11.5	10.6	10	9.7	9.3	27.4	19.6	16.9	15.6	14.5	13.5	13.2	12.6	30.5	26.7	23.1	21.3	19.7	18.5	17.9	17.2					
25	1	17.3	15.1	13.1	12	11.2	10.4	10.2	9.7	22.4	18.4	15.9	14.7	13.6	12.8	12.4	11.9	28.4	24.8	21.15	19.8	18.4	17.2	16.7	16					
32	1 1/4	13.7	11.9	10.3	9.5	8.8	8.3	8	7.7	21.1	15.4	13.3	12.3	11.4	10.6	10.3	9.9	23.9	20.9	18.1	16.7	15.5	14.5	14.1	13.5					
40	1 1/2	11.9	10.4	9	8.3	7.7	7.2	7	6.7	17.6	13.9	12	11.1	10.3	9.6	9.3	8.9	21.9	19.1	16.6	15.3	14.2	13.3	12.9	12.3					
50	2	9.6	8.4	7.2	6.7	6.2	5.8	5.6	5.4	15.9	11.8	10.2	9.4	8.7	8.2	7.9	7.6	19.1	16.7	14.5	13.3	12.4	11.6	11.3	10.8					
65	2 1/2	8.7	7.6	6.6	6.1	5.6	5.3	5.1	4.9	14.7	12.9	11.1	10.3	9.5	8.9	8.7	8.3	20	17.5	15.1	13.9	12.9	12.1	11.8	11.3					
80	3	7.1	6.2	5.4	5	4.6	4.3	4.2	4	12.9	11.2	9.7	9	8.3	7.8	7.6	7.2	17.9	15.6	13.5	12.4	11.6	10.8	10.5	10.1					
90	3 1/2	6.3	5.5	4.7	4.4	4	3.8	3.7	3.5	11.8	10.3	8.9	8.2	7.6	7.1	6.9	6.6	16.6	14.5	12.5	11.6	10.7	10	9.7	9.3					
100	4	5.6	4.9	4.2	3.9	3.6	3.4	3.3	3.1	11	9.6	8.3	7.7	7.1	6.6	6.5	6.2	15.6	13.6	11.8	10.9	10.1	9.4	9.2	8.8					
125	5	5	4.4	3.8	3.5	3.2	3	2.9	2.8	9.7	8.4	7.3	6.7	6.2	5.8	5.7	5.4	14	12.3	10.6	9.8	9.1	8.5	8.3	7.9					
150	6	4.2	3.7	3.2	2.9	2.7	2.5	2.5	2.4	8.8	7.7	6.7	6.1	5.7	5.3	5.2	5	13.6	11.9	10.3	9.5	8.8	8.2	8	7.6					
200	8	3.6	3.1	2.7	2.5	2.3	2.2	2.1	2	7.8	6.8	5.9	5.4	5	4.7	4.6	4.4	12.1	10.5	9.1	8.4	7.8	7.3	7.1	6.8					
250	10	3.2	2.8	2.4	2.2	2.1	1.9	1.9	1.8	7.1	6.2	5.3	4.9	4.6	4.3	4.2	4	9.7	8.5	7.3	6.8	6.3	5.9	5.7	5.5					
300	12	2.9	2.6	2.2	2	1.9	1.8	1.7	1.7	6.1	5.4	4.6	4.3	4	3.7	3.6	3.4	8.2	7.1	6.2	5.7	5.3	4.9	4.6	4.6					

The figures above are Nominal Working Pressure for 304L and 316L Seamless Stainless Steel Pipe under constant operating conditions, in MPa.

Where pressures or temperature fluctuations occur, increased safety factors should be adopted. Listed below are factors of safety recommended for varying pressure conditions.

- 5** To bursting pressure for no pressure fluctuations.
- 8** To bursting pressure for small/regular pressure fluctuations.
- 12** To bursting pressure for large/prolonged pressure fluctuations.

The figures given for nominal working pressures and factor of safety are for quick reference purposes only. Detailed design calculations should be in accordance with the applicable design standard.

WELDED PIPE

Nominal working pressure can be calculated by multiplying the figures in the tables by 0.85 (Weld Joint Efficiency factor).

BUTTWELD PIPE FITTINGS

SPECIFICATIONS:	ASTM A403
	ANSI B16.9
MATERIAL:	WELDED / SEAMLESS



SIZE		90° ELBOW				45° ELBOW		EQUAL		STUB END		CAPS
		LONG RADIUS		SHORT RADIUS		LONG RADIUS		TEE		TYPE B		
Inch	mm	304L	316L	304L	316L	304L	316L	304L	316L	304L	316L	316L
SCHEDULE 10												
1/2	15	★	★	☆	☆	★	★	★	★	☆	☆	☆
3/4	20	★	★	☆	☆	★	★	★	★	☆	☆	☆
1	25	★	★	☆	☆	★	★	★	★	☆	★	★
1 1/4	32	★	★	☆	☆	★	★	★	★	☆	★	★
1 1/2	40	★	★	☆	☆	★	★	★	★	☆	★	★
2	50	★	★	☆	☆	★	★	★	★	☆	★	★
2 1/2	65	★	★	☆	☆	★	★	★	★	☆	★	★
3	80	★	★	☆	☆	★	★	★	★	☆	★	★
3 1/2	90	★	★	☆	☆	★	★	★	★	☆	★	☆
4	100	★	★	☆	☆	★	★	★	★	☆	★	★
5	125	☆	★	☆	☆	☆	★	★	★	☆	☆	☆
6	150	★	★	☆	☆	★	★	★	★	☆	★	★
8	200	★	★	☆	☆	★	★	★	★	☆	★	★
10	250	★	★	☆	☆	☆	★	☆	★	☆	☆	☆
12	300	★	★	☆	☆	☆	★	☆	★	☆	☆	☆
SCHEDULE 40												
1/2	15	★	★	☆	☆	★	★	★	★	☆	☆	☆
3/4	20	★	★	☆	☆	★	★	★	★	☆	☆	★
1	25	★	★	☆	☆	★	★	★	★	☆	★	★
1 1/4	32	★	★	☆	☆	★	★	★	★	☆	★	★
1 1/2	40	★	★	☆	☆	★	★	★	★	☆	★	★
2	50	★	★	☆	☆	★	★	★	★	☆	★	★
2 1/2	65	★	★	☆	☆	★	★	★	★	☆	★	★
3	80	★	★	☆	☆	★	★	★	★	☆	★	★
3 1/2	90	★	★	☆	☆	★	★	★	★	☆	★	☆
4	100	★	★	☆	☆	★	★	★	★	☆	★	★
5	125	☆	★	☆	☆	☆	★	☆	★	☆	☆	☆
6	150	★	★	☆	☆	★	★	★	★	☆	★	★
8	200	★	★	☆	☆	★	★	★	★	☆	★	★
10	250	★	★	☆	☆	☆	★	☆	★	☆	☆	☆
12	300	★	★	☆	☆	☆	★	☆	★	☆	☆	☆

NOTE: SCH 80 FITTINGS ARE AVAILABLE ON REQUEST

REDUCING BUTTWELD PIPE FITTINGS

SPECIFICATIONS: ASTM A403

ANSI B16.9

MATERIAL:

WELDED / SEAMLESS



SIZE		CONCENTRIC REDUCER				ECCENTRIC REDUCER		REDUCING TEE	
Inch	mm	SCH 10		SCH 40		SCH 10	SCH 40	SCH10	SCH 40
		304L	316L	304L	316L	316L	316L	316L	316L
3/4 x 1/2	20 x 15	☆	★	☆	★	☆	☆	☆	☆
1 x 1/2	25 x 15	☆	★	☆	★	☆	☆	☆	☆
1 x 3/4	25 x 20	☆	★	☆	★	★	★	☆	☆
1 1/4 x 1/2	32 x 15	☆	★	☆	★	☆	☆		
1 1/4 x 3/4	32 x 20	☆	★	☆	★	☆	☆	☆	☆
1 1/4 x 1	32 x 25	☆	★	☆	★	☆	☆	☆	☆
1 1/2 x 1/2	40 x 15	☆	★	☆	★	☆	☆		
1 1/2 x 3/4	40 x 20	☆	★	☆	★	★	★	☆	☆
1 1/2 x 1	40 x 25	☆	★	☆	★	★	★	☆	☆
1 1/2 x 1 1/4	40 x 32	☆	★	☆	★	★	★	☆	☆
2 x 3/4	50 x 20	☆	☆	☆	☆	☆	☆	☆	☆
2 x 1	50 x 25	☆	★	☆	★	★	★	☆	☆
2 x 1 1/4	50 x 32	☆	★	☆	★	★	★	☆	☆
2 x 1 1/2	50 x 40	☆	★	☆	★	★	★	☆	☆
2 1/2 x 1	65 x 25	☆	★	☆	★	☆	☆	☆	☆
2 1/2 x 1 1/4	65 x 32	☆	☆	☆	☆	☆	☆	☆	☆
2 1/2 x 1 1/2	65 x 40	☆	★	☆	★	★	★	☆	☆
2 1/2 x 2	65 x 50	☆	★	☆	★	★	★	☆	☆
3 x 1	80 x 25	☆	★	☆	★	☆	☆	☆	☆
3 x 1 1/4	80 x 32	☆	☆	☆	☆	☆	☆	☆	☆
3 x 1 1/2	80 x 40	☆	★	☆	★	★	★	☆	☆
3 x 2	80 x 50	☆	★	☆	★	★	★	☆	☆
3 x 2 1/2	80 x 65	☆	★	☆	★	★	★	☆	☆
3 1/2 x 1 1/2	90 x 40	☆	☆	☆	☆	☆	☆	☆	☆
3 1/2 x 2	90 x 50	☆	☆	☆	☆	☆	☆	☆	☆
3 1/2 x 2 1/2	90 x 65	☆	☆	☆	☆	☆	☆	☆	☆
3 1/2 x 3	90 x 80	☆	☆	☆	☆	☆	☆	☆	☆
4 x 1 1/2	100 x 40	☆	★	☆	☆	☆	☆	☆	☆
4 x 2	100 x 50	☆	★	☆	★	★	★	☆	☆
4 x 2 1/2	100 x 65	☆	★	☆	★	★	★	☆	☆
4 x 3	100 x 80	☆	★	☆	★	★	★	☆	☆
4 x 3 1/2	100 x 90	☆	☆	☆	☆	☆	☆	☆	☆
5 x 2	125 x 50	☆	☆	☆	☆	☆	☆	☆	☆
5 x 2 1/2	125 x 65	☆	☆	☆	☆	☆	☆	☆	☆
5 x 3	125 x 80	☆	☆	☆	☆	☆	☆	☆	☆
5 x 3 1/2	125 x 90	☆	☆	☆	☆	☆	☆	☆	☆
5 x 4	125 x 100	☆	☆	☆	☆	☆	☆	☆	☆
6 x 2	150 x 50	☆	☆	☆	☆	☆	☆	☆	☆
6 x 2 1/2	150 x 65	☆	☆	☆	☆	☆	☆	☆	☆
6 x 3	150 x 80	☆	★	☆	★	★	★	☆	☆
6 x 3 1/2	150 x 90	☆	☆	☆	☆	☆	☆	☆	☆
6 x 4	150 x 100	☆	★	☆	★	★	★	☆	☆
6 x 5	150 x 125	☆	☆	☆	☆	☆	☆	☆	☆
8 x 3	200 x 80	☆	☆	☆	☆	☆	☆	☆	☆
8 x 3 1/2	200 x 90	☆	☆	☆	☆	☆	☆	☆	☆
8 x 4	200 x 100	☆	★	☆	★	★	★	☆	☆
8 x 5	200 x 125	☆	☆	☆	☆	☆	☆	☆	☆
8 x 6	200 x 150	☆	★	☆	★	★	★	☆	☆
10 x 4	250 x 100	☆	☆	☆	☆	☆	☆	☆	☆
10 x 5	250 x 125	☆	☆	☆	☆	☆	☆	☆	☆
10 x 6	250 x 150	☆	★	☆	★	☆	☆	☆	☆
10 x 8	250 x 200	☆	★	☆	★	★	★	☆	☆
12 x 5	300 x 125	☆	☆	☆	☆	☆	☆	☆	☆
12 x 6	300 x 150	☆	☆	☆	☆	☆	☆	☆	☆
12 x 8	300 x 200	☆	★	☆	★	★	☆	☆	☆
12 x 10	300 x 250	☆	★	☆	★	★	☆	☆	☆

TECHNICAL DATA

BUTTWELD PIPE FITTING DIMENSIONS

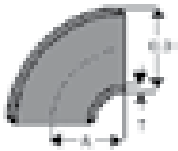

90° SHORT
RADIUS ELBOW



90° LONG
RADIUS ELBOW



45° ELBOW



EQUAL TEE

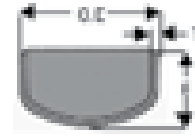

CAP

NOMINAL PIPE SIZE		OUTSIDE DIAMETER	WALL THICKNESS SCHEDULE				ELBOW			EQUAL TEE	CAP
							90°		45°		
		T				L/R	S/R	L/R			
Inch	mm	O.D.	5S	10S	40S	80S	A	A	B	C,M	E
1/2	15	21.3	1.65	2.11	2.77	3.73	38.1		16	25.4	25.4
3/4	20	26.7	1.65	2.11	2.87	3.91	28.5		11	28.6	25.4
1	25	33.4	1.65	2.77	3.38	4.55	38.1	25.4	22	38.1	38
1 1/4	32	42.2	1.65	2.77	3.56	4.85	47.5	32	25	47.6	38
1 1/2	40	48.3	1.64	2.77	3.68	5.08	57	38	29	57.2	38
2	50	60.3	1.65	2.77	3.91	5.54	76	51	35	63.5	38
2 1/2	65	73	2.11	3.05	5.16	7.01	95	63.5	45	76.2	38
3	80	88.9	2.11	3.05	5.49	7.62	114.5	76	51	85.7	51
3 1/2	90	101.6	2.11	3.05	5.74	8.08	133.5	89	57	95.3	64
4	100	114.3	2.11	3.05	6.02	8.56	152.5	101.5	64	104.8	64
5	125	141.3	2.77	3.4	6.55	9.52	190.5	127	79	123.8	76
6	150	168.3	2.77	3.4	7.11	10.97	228.5	152.5	95	142.9	89
8	200	219.1	2.77	3.76	8.18	12.7	305	203	127	177.8	102
10	250	273	3.4	4.19	9.27	12.7	381	254	159	215.9	127
12	300	323.9	3.96	4.57	9.52	12.7	457	305	191	254	152

NOMINAL PIPE SIZE		OUTSIDE DIAMETER	STUB END TYPE B		
			MSS		
Inch	mm	O.D.	G	F	R
1/2	15	21.3	35	51	0.8
3/4	20	26.7	43	51	0.8
1	25	33.4	51	51	0.8
1 1/4	32	42.2	64	51	0.8
1 1/2	40	48.3	73	51	0.8
2	50	60.3	92	64	0.8
2 1/2	65	73	105	64	0.8
3	80	88.9	127	64	0.8
3 1/2	90	101.6	140	76	0.8
4	100	114.3	157	76	1.6
5	125	141.3	186	76	1.6
6	150	168.3	216	89	1.6
8	200	219.1	270	102	1.6
10	250	273	324	127	1.6
12	300	323.9	381	152	1.6

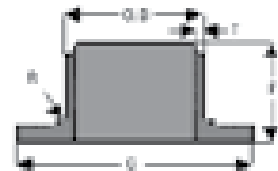

TECHNICAL DATA

BUTTWELD PIPE FITTING DIMENSIONS

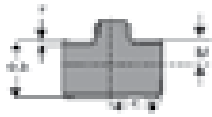

REDUCING TEE



CONCENTRIC REDUCER



ECCENTRIC REDUCER

NOMINAL PIPE SIZE			REDUCING TEE		REDUCERS CONCENTRIC & ECCENTRIC
Inch		mm	C	M	H
3/4 x	1/2	20 x 15	28.6	28.6	38.1
1 x	1/2	25 x 15	38.1	38.1	50.8
x	3/4	25 x 20		38.1	
1 1/4 x	1/2	32 x 15	47.6	47.6	50.8
x	3/4	32 x 20		47.6	
x	1	32 x 25		47.6	
1 1/2 x	1/2	40 x 15	57.2	57.2	63.5
x	3/4	40 x 20		57.2	
x	1	40 x 25		57.2	
x	1 1/4	40 x 32		57.2	
2 x	3/4	50 x 20	63.5	44.5	76.2
x	1	50 x 25		50.8	
x	1 1/4	50 x 32		57.2	
x	1 1/2	50 x 40		60.3	
2 1/2 x	1	65 x 25	76.2	57.2	88.9
x	1 1/4	65 x 32		63.5	
x	1 1/2	65 x 40		66.7	
x	2	65 x 50		69.9	
3 x	1	80 x 25	85.7	66.7	88.9
x	1 1/4	80 x 32		69.9	
x	1 1/2	80 x 40		73	
x	2	80 x 50		76.2	
x	2 1/2	80 x 65		82.6	
3 1/2 x	1 1/2	90 x 40	95.3	79.4	101.6
x	2	90 x 50		82.6	
x	2 1/2	90 x 65		88.9	
x	3	60 x 80		92.1	
4 x	1 1/2	100 x 40	104.8	85.7	101.6
x	2	100 x 50		88.9	
x	2 1/2	100 x 65		95.3	
x	3	100 x 80		98.4	
x	3 1/2	100 x 90		101.6	
5 x	2	125 x 50	123.8	104.8	127
x	2 1/2	125 x 65		108	
x	3	125 x 80		111.1	
x	3 1/2	125 x 90		114.3	
x	4	125 x 100		117.5	
6 x	2	150 x 50	142.9	117.5	139.7
x	2 1/2	150 x 65		120.7	
x	3	150 x 80		123.8	
x	3 1/2	150 x 90		127	
x	4	150 x 100		130.1	
x	5	150 x 125		136.5	
8 x	3	200 x 80	178	149.1	152
x	3 1/2	200 x 90		152	
x	4	200 x 100		155	
x	5	200 x 125		162	
x	6	200 x 150		168	
10 x	4	250 x 100	216	184	178
x	5	250 x 125		191	
x	6	250 x 150		194	
x	8	250 x 200		203	
12 x	5	300 x 125	254	216	203
x	6	300 x 150		219	
x	8	300 x 200		229	
x	10	300 x 250		241	

150LB BSP THREADED FITTINGS

SPECIFICATIONS:	ASTM A351-77	
GRADE:	316	
THREAD:	BSP (MALE-TAPER, FEMALE PARALLEL)	
PRESSURE:	NOMINAL	1000kPA
	WORKING	2000kPA TEST



Inch	mm	SOCKET ROUND	NIPPLE HEX	BARRELL NIPPLE	TOE NIPPLE	UNION 3 PCE	ELBOW 90° FEM	ELBOW 90° M/F	ELBOW 45° F/F	TEE FEM	HEX CAP	HEX PLUG FEM	LOCK NUT	HOSE TAIL
1/8	6	★	★	★	★	★	★	★	☆	★	★	★	★	★
1/4	8	★	★	★	★	★	★	★	★	★	★	★	★	★
3/8	10	★	★	★	★	★	★	★	★	★	★	★	★	★
1/2	15	★	★	★	★	★	★	★	★	★	★	★	★	★
3/4	20	★	★	★	★	★	★	★	★	★	★	★	★	★
1	25	★	★	★	★	★	★	★	★	★	★	★	★	★
1 1/4	32	★	★	★	★	★	★	★	★	★	★	★	★	★
1 1/2	40	★	★	★	★	★	★	★	★	★	★	★	★	★
2	50	★	★	★	★	★	★	★	★	★	★	★	★	★
2 1/2	65	★	★	★	★	★	★	★	★	★	★	★	★	☆
3	80	★	★	★	★	★	★	★	★	★	★	★	★	☆
4	100	★	★	★	★	★	★	★	☆	★	★	★	★	☆
6	150	☆	☆	☆	☆	☆	☆	☆	☆	☆	☆	☆	☆	☆



Inch	mm	HEX REDUCING BUSH	HEX REDUCING NIPPLE	REDUCING SOCKET
1/4 x 1/8	8 x 6	★	★	☆
3/8 x 1/8	10 x 6	★	★	☆
3/8 x 1/4	10 x 8	★	★	★
1/2 x 1/8	15 x 6	★	★	☆
1/2 x 1/4	15 x 8	★	★	★
1/2 x 3/8	15 x 10	★	★	★
3/4 x 1/8	20 x 6	★	★	☆
3/4 x 1/4	20 x 8	★	★	☆
3/4 x 1/8	20 x 10	★	★	★
3/4 x 1/2	20 x 15	★	★	★
1 x 1/4	25 x 8	★	★	☆
1 x 3/8	25 x 10	★	★	☆
1 x 1/2	25 x 15	★	★	★
1 x 3/4	25 x 20	★	★	★
1 1/2 x 3/8	32 x 10	★	★	☆
1 1/4 x 1/2	32 x 15	★	★	☆
1 1/4 x 3/4	32 x 20	★	★	☆
1 1/4 x 1	32 x 25	★	★	★
1 1/2 x 1/2	40 x 15	★	★	☆
1 1/2 x 3/4	40 x 20	★	★	☆
1 1/2 x 1	40 x 25	★	★	★
1 1/2 x 1 1/4	40 x 32	★	★	★
2 x 3/4	50 x 20	★	★	☆
2 x 1	50 x 25	★	★	★
2 x 1 1/4	50 x 32	★	★	★
2 x 1 1/2	50 x 40	★	★	★
2 1/2 x 1 1/4	65 x 32	★	★	☆
2 1/2 x 2	65 x 50	★	★	☆
3 x 2	80 x 50	★	★	☆
3 x 2 1/2	80 x 65	☆	☆	☆
4 x 3	100 x 80	☆	☆	☆

150LB BSP THREADED FITTINGS TECHNICAL DATA

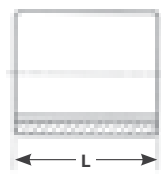

SOCKET

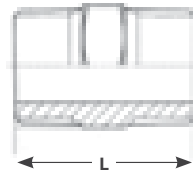

HEX NIPPLE

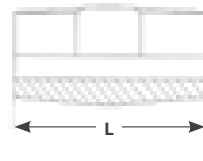

BARREL NIPPLE

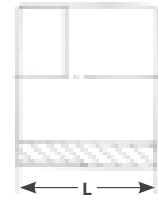

TOE NIPPLE

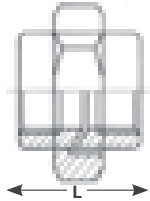

UNION 3 PCE F/F

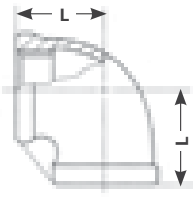

ELBOW 90Deg F/F

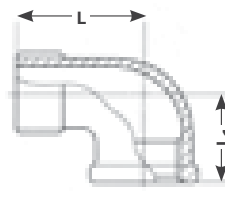

ELBOW 90Deg M/F

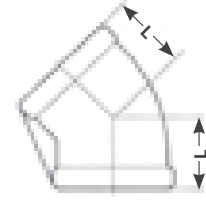

ELBOW 45Deg F/F

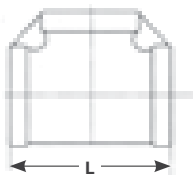

TEE F/F

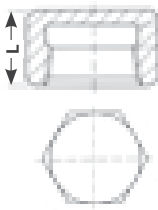

HEXAGON CAP

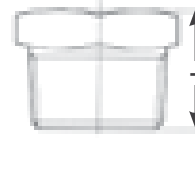

HEXAGON PLUG

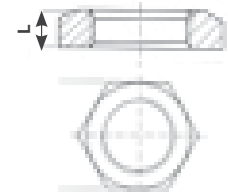

LOCK NUT

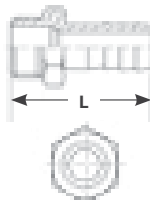

HOSE TAIL

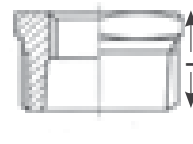

HEX REDUCING BUSH

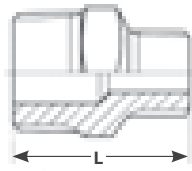

HEX REDUCING NIPPLE

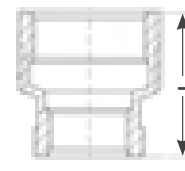

REDUCING SOCKET

SIZE mm	6		8		10		15		20		25		32		40		50		65		80		100	
LENGTH mm	L	L ₁	L	L ₁	L	L ₁	L	L ₁	L	L ₁	L	L ₁	L	L ₁	L	L ₁	L	L ₁	L	L ₁	L	L ₁	L	L ₁
FITTING																								
Socket	20		25		26		34		36		43		48		48		56		65		71		83	
Hexagon Nipple	31		33		42		50		51		63		59		64		68		73		86		90	
Barrel Nipple	40		40		40		60		60		60		80		80		100		100		120		120	
Toe Nipple	30		30		30		35		40		40		50		50		50		60		70		80	
Union 3 Pce F/F	37		37		39		41		42		51		52		56		60		75		89		99	
Elbow 90Deg F/F	17		19.5		24		29		32		37		44		48		55.5		67		77		96	
Elbow 90Deg M/F	18	26	21	29	24	36	27	41	33	47	37	53	44	63	47	69	59	80	66	105	77	113	98	130
Elbow 45Deg F/F	16		17		19		21		24		28		33		36		42		49		54		65	
Tee F/F	18		19.5		23		29		32.5		37		45		48		56.5		68		79		97	
Hexagon Cap	16		20		21		22.5		23		26		29		32		35		42		46		55	
Hexagon Plug	17		18		23.5		28		28		34		35		36		37.5		40		45		51	
Lock Nut	8.5		8.5		9		9		10		11		12		13		13.5		18		21		22	
Hose Tail			46.5		51.5		62.5		72.5		82		80		93		110		136		147		158	
Hex Reducing Bush			22.5		23		25.5		26.5		33.5		34		36		36		49		50		51	
Hex Reducing Nipple			31.5		35		39		42		46		52		53		58		65		73		83	
Reducing Socket			28.5		41		45		45		50		50		57		67		76		85		96	

150LB BSP THREADED FITTINGS TECHNCIAL DATA

BRITISH STANDARD THREADS (BSP)

Taper 1 in 16 on diagram (Shown exaggerated in diagram)

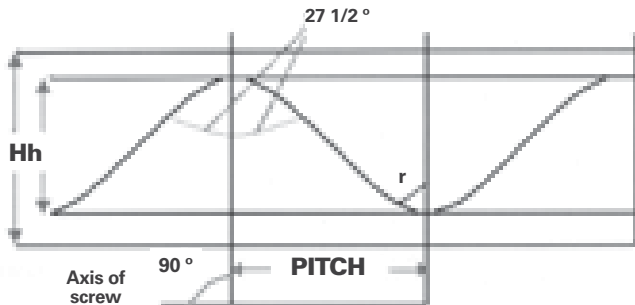

Taper

- $H = 0.960237xp$
- $h = 0.610327xp$
- $r = 0.127278xp$

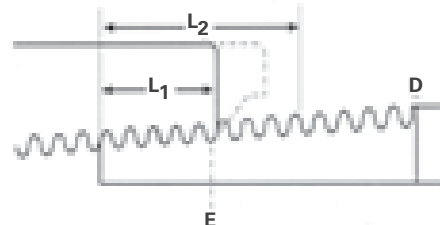

NOMINAL BORE OF PIPE		OUTSIDE DIAMETER OF S.S. PIPE	NUMBER OF THREADS PER INCH	PITCH	DEPTH OF THREAD	DIAMETER AT GAUGE PLANE (GAUGE DIA.)	DISTANCE OF GAUGE DIA. (GAUGE LENGTH)	LENGTH OF USEFUL THREAD
NB	Inch	D			h	E	L ₁	L ₂
6	1/8	0.405	28	0.03571	0.0229	0.383	0.1563	0.2545
8	1/4	0.540	19	0.05263	0.0337	0.518	0.2367	0.3314
10	3/8	0.675	19	0.05263	0.0337	0.656	0.2500	0.3947
15	1/2	0.840	14	0.07143	0.0457	0.825	0.3214	0.5178
20	3/4	1.050	14	0.07143	0.0457	1.041	0.3750	0.5714
25	1	1.315	11	0.09091	0.0582	1.309	0.4091	0.6591
32	1 1/4	1.660	11	0.09091	0.0582	1.650	0.5000	0.7500
40	1 1/2	1.900	11	0.09091	0.0582	1.882	0.5000	0.7500
50	2	2.375	11	0.09091	0.0582	2.347	0.6250	0.9204
65	2 1/2	2.875	11	0.09091	0.0582	2.950	0.6875	1.0511
80	3	3.500	11	0.09091	0.0582	3.460	0.8125	1.1761
100	4	4.500	11	0.09091	0.0582	4.450	1.0000	1.4091
125	5	5.563	11	0.09091	0.0582	5.40	1.1250	1.5795
150	6	6.625	11	0.09091	0.0582	6.450	1.1250	1.5795

PIPE PRODUCTS

3000LB FITTINGS

SPECIFICATIONS: ASTM A182/ANSI B16/11
NPT THREAD

GRADE: 316

PRESSURE: 3000LB (ICPA)



Inch	mm	FULL COUPLING	HALF COUPLING	UNION 3 PCE	90° ELBOW FEMALE	45° ELBOW FEMALE	TEE FEMALE	HEX NIPPLE	HEX PLUG
1/8	6	★	☆	★	☆	☆	☆	★	★
1/4	8	★	☆	★	★	☆	★	★	★
3/8	10	★	☆	★	★	☆	★	★	★
1/2	15	★	☆	★	★	☆	★	★	★
3/4	20	★	☆	★	★	☆	★	★	★
1	25	★	☆	★	★	☆	★	★	★
1 1/4	32	★	☆	★	★	☆	★	★	★
1 1/2	40	★	☆	★	★	☆	★	★	★
2	50	★	☆	★	★	☆	★	★	★



SIZE - NOMINAL		HEX REDUCING BUSH	HEX REDUCING NIPPLE
Inch	mm		
1/4 x 1/8	8 x 6	★	★
3/8 x 1/8	10 x 6	★	★
3/8 x 1/4	10 x 8	★	★
1/2 x 1/4	15 x 8	★	★
1/2 x 3/8	15 x 10	★	★
3/4 x 1/2	20 x 15	★	★
1 x 1/4	25 x 8	★	★
1 x 1/2	25 x 15	★	★
1 x 3/4	25 x 20	★	★
1 1/4 x 3/4	32 x 20	★	★
1 1/4 x 1	32 x 25	★	★
1 1/2 x 3/4	40 x 20	★	★
1 1/2 x 1	40 x 25	★	★
2 x 3/4	50 x 20	★	★
2 x 1	50 x 25	★	★
2 x 1 1/2	50 x 40	★	★

SPECIFICATIONS: ASTM A182/ANSI B16/11
3000LB SOCKETWELD

GRADE: 316

PRESSURE: 3000LB (ICPA)



SCHEDULE - NOMINAL		FULL COUPLING	HALF COUPLING	UNION 3 PCE	90° ELBOW FEMALE	45° ELBOW FEMALE	EQUAL TEE FEMALE	CAP
Inch	mm							
1/4	8	☆	☆	☆	☆	☆	☆	☆
3/8	10	☆	☆	☆	☆	☆	☆	☆
1/2	15	☆	☆	☆	☆	☆	☆	☆
3/4	20	☆	☆	☆	☆	☆	☆	☆
1	25	☆	☆	☆	☆	☆	☆	☆
1 1/4	32	☆	☆	☆	☆	☆	☆	☆
1 1/2	40	☆	☆	☆	☆	☆	☆	☆
2	50	☆	☆	☆	☆	☆	☆	☆

3000LB NPT THREADED FITTINGS TECHNICAL DATA

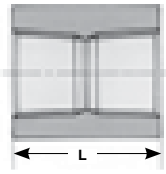

FULL COUPLING

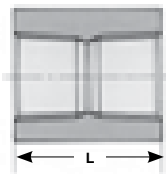

HALF COUPLING

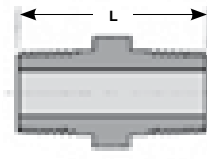

HEXAGON NIPPLE



UNION 3 PCE F/F

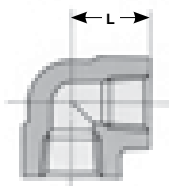

ELBOW 90 DEG F/F

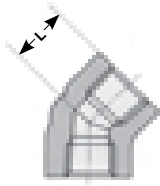

ELBOW 45 DEG F/F

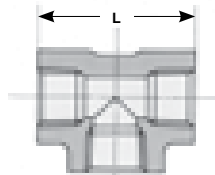

TEE F/F

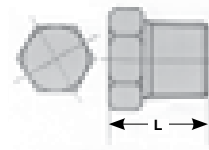

HEXAGON PLUG

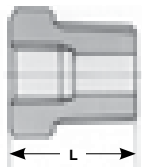

HEX REDUCING BUSH

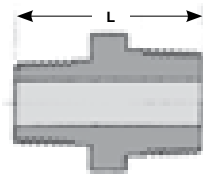

HEX REDUCING NIPPLE

3000LB NPT THREADED FITTINGS
TECHNICAL DATA

SIZE mm	6	8	10	15	20	25	32	40	50
LENGTH mm	L	L	L	L	L	L	L	L	L
FITTING									
Full Coupling	32	35	38	48	51	60	67	79	86
Half Coupling	16	17.5	19	24	25.5	30	33.5	39.5	43
Hexagon Nipple	26	36	36	47	48	59	60	62	68
Union 3 Pce F/F	41.4	41.4	46	49	56.9	62	71.1	76.5	86.1
Elbow 90 Deg F/F	21	25	28	33	38	44	51	60	64
Elbow 45 Deg F/F	17	19	22	25	28	33	35	43	44
Tee F/F	21	25	28	33	38	44	51	60	64
Hexagon Plug	16	17	21	22	26	29	31	37	38
Hex Reducing Bush		14	17	19	22	25	28	29	31
Hex Reducing Nipple			19	24	30	35	46	50	65

TECHNICAL DATA

DIMENSIONS OF PIPE THREAD

AMERICAN STANDARD THREADS (NPT)

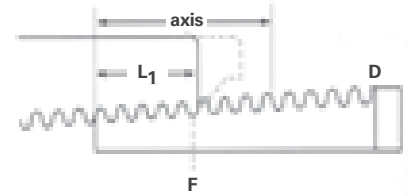
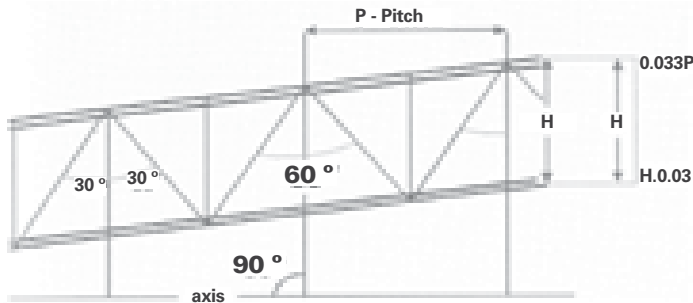

Taper

$$L_2 = (0.8D - 6.8)1/n$$

Straight Pipe Threads: the pitch, angle and depth of thread are the same as the corresponding dimensions of the taper threads

NOMINAL BORE OF PIPE		OUTSIDE DIAMETER OF S.S. PIPE	NUMBER OF THREADS PER INCH	PITCH	HAND TIGHT	EFFECTIVE ENGAGEMENT EXTERNAL	THREAD LENGTH THREAD	DEPTH
NB	Inch	D	n	P	L ₁	E ₁	L ₂	h
6	1/8	0.405	27	0.03704	0.180	0.37476	0.2639	0.02963
8	1/4	0.540	18	0.05556	0.200	0.48989	0.4018	0.04444
10	3/8	0.675	18	0.05556	0.240	0.62701	0.4078	0.04444
15	1/2	0.840	14	0.07143	0.230	0.77843	0.5337	0.05714
20	3/4	1.050	14	0.07143	0.339	0.98887	0.5457	0.05714
25	1	1.315	11 1/2	0.08696	0.400	1.23863	0.6828	0.06957
32	1 1/4	1.660	11 1/2	0.08696	0.420	1.56338	0.7068	0.06957
40	1 1/2	1.900	11 1/2	0.08696	0.420	1.82234	0.7235	0.06957
50	2	2.375	11 1/2	0.08696	0.436	2.29627	0.7665	0.06957
65	2 1/2	2.875	8	0.12500	0.682	2.76216	1.1375	0.10000
80	3	3.500	8	0.12500	0.766	3.38850	1.2000	0.10000
90	3 1/2	4.000	8	0.12500	0.821	3.88881	1.2500	0.10000
100	4	4.500	8	0.12500	0.844	4.38712	1.3000	0.10000
125	5	5.563	8	0.12500	0.937	5.44929	1.4063	0.10000
150	6	6.625	8	0.12500	0.958	6.50597	1.5121	0.10000

TECHNICAL DATA

SOCKET WELD FITTINGS

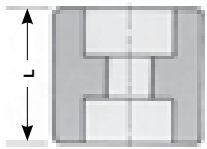

FULL COUPLING

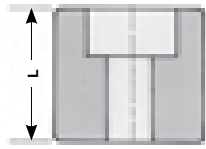

HALF COUPLING

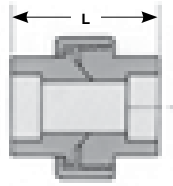

UNION 3 PCE F/F

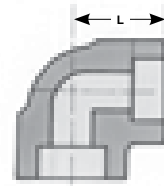

ELBOW 90 DEG F/F

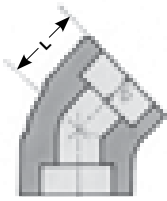

ELBOW 45 DEG F/F

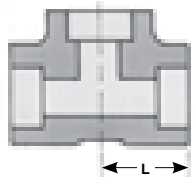

TEE F/F

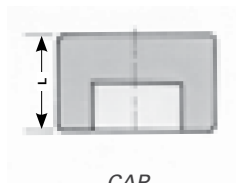

CAP

SIZE mm	6	8	10	15	20	25	32	40	50
LENGTH mm	L	L	L	L	L	L	L	L	L
FITTING									
Full Coupling	25.4	25.4	28.7	35	38.1	44.5	47.8	50.8	63.5
Half Coupling	25.4	25.4	28.7	35	38.1	44.5	47.8	50.8	63.5
Union 3 Pce F/F	41.4	41.4	46	49.3	57.2	63.5	71.4	76.2	85.9
Elbow 90 Deg F/F	20.6	20.6	24.7	28.7	33.3	38.1	44.5	50.8	60.5
Elbow 45 Deg F/F	17.5	17.5	19	22.4	25.4	28.7	33.3	35	42.4
Tee F/F	20.6	20.6	24.7	28.7	33.3	38.1	44.5	50.8	60.5
Cap	17.5	17.5	19	22.4	24.4	27	30.3	31.8	38.1

FORGED FLANGES

SPECIFICATIONS: ASTM A182 ANSI B16.5
RAISED FACE FLANGES

TYPE: SLIP ON RFSO
WELD NECK RFWN SCH10,40 & 80
BLIND RFB

CLASS: 150LB, 300LB, 600LB

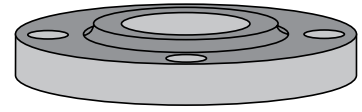

GRADE	SIZE N.B.	SLIP ON RAISED FACE			WELD NECK RAISED FACE			BLIND RAISED FACE			
		mm	150lb	300lb	600lb	150lb	300lb	600lb	150lb	300lb	600lb
304L	15	☆	☆	☆	☆	☆	☆	☆	☆	☆	☆
	20	☆	☆	☆	☆	☆	☆	★	☆	☆	☆
	25	★	☆	☆	★	☆	☆	★	☆	☆	☆
	32	★	☆	☆	★	☆	☆	★	☆	☆	☆
	40	★	☆	☆	★	☆	☆	★	☆	☆	☆
	50	★	☆	☆	★	☆	☆	★	★	☆	☆
	65	★	☆	☆	★	☆	☆	★	☆	☆	☆
	80	★	☆	☆	★	☆	☆	★	★	☆	☆
	100	★	☆	☆	★	☆	☆	★	★	☆	☆
	150	★	☆	☆	★	☆	☆	★	★	☆	☆
316L	200	★	☆	☆	★	☆	☆	★	☆	☆	☆
	250	★	☆	☆	☆	☆	☆	☆	☆	☆	☆
	300	☆	☆	☆	☆	☆	☆	☆	☆	☆	☆
	15	★	☆	☆	★	☆	☆	★	☆	☆	☆
	20	★	☆	☆	★	☆	☆	★	☆	☆	☆
	25	★	★	☆	★	☆	☆	★	★	☆	☆
	32	★	★	☆	★	☆	☆	★	★	☆	☆
	40	★	★	☆	★	☆	☆	★	★	☆	☆
	50	★	★	☆	★	☆	☆	★	★	☆	☆
	65	★	★	☆	★	☆	☆	★	★	☆	☆
	80	★	★	☆	★	☆	☆	★	★	☆	☆
	100	★	★	☆	★	☆	☆	★	★	☆	☆
	125	★	☆	☆	★	☆	☆	★	☆	☆	☆
	150	★	★	☆	★	☆	☆	★	★	☆	☆
	200	★	☆	☆	★	☆	☆	★	☆	☆	☆
	250	★	☆	☆	☆	☆	☆	★	☆	☆	☆
300	★	☆	☆	☆	☆	☆	★	☆	☆	☆	
350	★	☆	☆	☆	☆	☆	★	☆	☆	☆	
400	★	☆	☆	☆	☆	☆	★	☆	☆	☆	
450	☆	☆	☆	☆	☆	☆	☆	☆	☆	☆	
500	★	☆	☆	☆	☆	☆	☆	☆	☆	☆	
600	★	☆	☆	☆	☆	☆	☆	☆	☆	☆	

TECHNICAL DATA

FORGED FLANGE DIMENSIONS

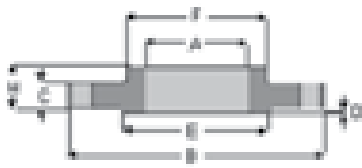

SLIP-ON

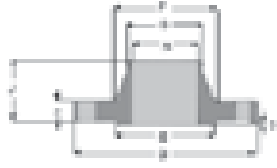

WELD NECK



BLIND

BOLT	SIZE	OUTSIDE DIA. OF PIPE	OUTSIDE DIA. MIN.	THICK. MIN.	RAISED FACE THICK.	RAISED FACE DIA.	HUB DIA.	HUB DIA. BEGIN OF CHAMFER	LENGTH/HUB SLIP-ON W.NECK	BOLT CIRCLE DIA.	BOLT HOLE DIA.	# HOLES	
	mm	A	B	C	D	E	F	G	H	J	K	L	M
150lb	15	21.3	90	11.5	1.6	34.9	30	21.5	16	48	60.5	16	4
	20	26.9	98	13	1.6	42.9	38	26.5	16	52	70	16	4
	25	33.7	108	14.5	1.6	50.8	49	34.5	17	56	79.5	16	4
	32	42.2	117	16	1.6	63.5	59	43	21	57	89	16	4
	40	48.3	127	17.5	1.6	73	65	48.5	22	62	98.5	16	4
	50	60.3	152	19.5	1.6	92.1	78	62	25	64	120.5	20	4
	65	73	178	25	1.6	104.8	90	74.7	29	70	139.5	20	4
	80	88.9	191	25	1.6	127	108	91	30	70	152.5	20	4
	100	114.3	229	25	1.6	157.2	135	116	32	76	190.5	20	8
	150	168.3	279	25.5	1.6	215.9	192	178	40	89	241.5	23	8
	200	219.1	343	29	1.6	269.9	246	229	44	102	298.5	23	8
	250	273	406	30.5	1.6	323.8	305	276	49	102	362	26	12
	300	323.9	483	32.0	1.6	381.0	365	324.0	56	114	432.0	26	12
	350	355.6	535	35.0	1.6	412.8	400	355.5	57	127	476.5	29	12
	400	406.4	600	37.0	1.6	469.9	457	406.5	64	127	540.0	29	16
	450	457.2	635	40.0	1.6	533.4	505	457.0	68	140	578.0	32	16
500	508.0	700	43.0	1.6	584.2	559	508.0	73	145	635.0	32	20	
600	609.6	815	48	1.6	692.2	664	609.5	83	152	749.5	35	20	
300lb	15	21.3	95	14.5	1.6	34.9	38	21.5	22	52	66.5	16	4
	20	26.9	117	16	1.6	42.9	48	26.5	25	57	82.5	20	4
	25	33.7	124	17.5	1.6	50.8	54	33.5	27	62	89	20	4
	32	42.2	133	19.5	1.6	63.5	64	42	27	65	98.5	20	4
	40	48.3	156	21	1.6	73	70	48.5	30	68	114.5	23	4
	50	60.3	165	22.5	1.6	92.1	84	60.5	33	70	127	20	8
	65	73	191	25	1.6	104.8	100	73	38	76	149	23	8
	80	88.9	210	29	1.6	127	118	89	43	79	168.5	23	8
	100	114.3	254	30	1.6	157.2	146	114.5	48	86	200	23	8
	150	168.3	318	37	1.6	215.9	206	168.5	52	98	270	23	12
	200	219.1	381	41.5	1.6	269.9	260	219	62	111	330	26	12
	250	273	445	48	1.6	323.8	321	273	67	117	387.5	29	16
	300	323.9	520	51.0	1.6	381.0	375	324.0	73	130	451.0	32	16
	350	355.6	585	54.0	1.6	412.8	426	355.5	76	143	514.5	32	20
	400	406.4	650	57.5	1.6	469.9	483	406.5	83	146	571.5	35	20
	450	457.2	710	60.5	1.6	533.4	533	457.0	89	159	628.5	35	24
500	508.0	775	63.5	1.6	584.2	587	508.0	95	162	686.0	35	24	
600	609.6	915	70.0	1.6	692.2	702	609.5	106	168	813.0	42	24	

PLATE FLANGES

SPECIFICATIONS: AS2129
TABLE FLANGES

TYPE: SLIP-ON WELD SOW
BLIND BL

CLASS: TABLE D, E, F & H

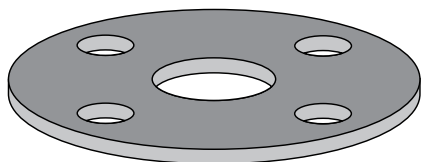

SLIP-ON

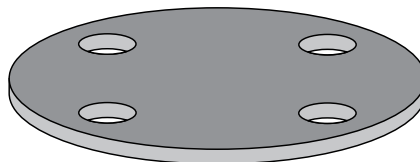

BLIND

GRADE	SIZE N.B. mm	TABLE D		TABLE E		TABLE F		TABLE H	
		SLIP-ON	BLIND	SLIP-ON	BLIND	SLIP-ON	BLIND	SLIP-ON	BLIND
304L	15			★	★	☆	☆	★	☆
	20			★	★	☆	☆	★	☆
	25			★	★	★	☆	★	☆
	32			★	★	★	☆	★	☆
	40	★	★	★	★	★	☆	★	☆
	50	★	★	★	★	★	☆	★	☆
	65	★	★	★	★	☆	☆	★	☆
	80	★	★	★	★	★	☆	★	☆
	100	★	★	★	★	☆	☆	★	☆
	125	★	★	★	★			☆	☆
150	★	★	★	★	★	☆	☆	☆	
200	★	★	★	★	☆	☆	☆	☆	
250	★	★	★	★	☆	☆	☆	☆	
300	★	★	★	★	☆	☆	☆	☆	
316L	15			★	★	★	☆	★	☆
	20			★	★	★	☆	★	☆
	25			★	★	☆	☆	★	☆
	32			★	★	☆	☆	★	☆
	40	★	★	★	★	☆	☆	★	☆
	50	★	★	★	★	★	☆	★	☆
	65	★	★	★	★	★	☆	★	☆
	80	★	★	★	★	★	☆	★	☆
	100	★	★	★	★	☆	☆	★	☆
	125	★	★	★	★			☆	☆
150	★	★	★	★	☆	☆	☆	☆	
200	★	★	★	★	☆	☆	☆	☆	
250	★	★	★	★	☆	☆	☆	☆	
300	★	★	★	★	☆	☆	☆	☆	

NOTE: Plate Flanges above 300mm are made to manufacture.
Non Standard Flanges are our speciality.

TECHNICAL DATA

PLATE FLANGE DIMENSIONS

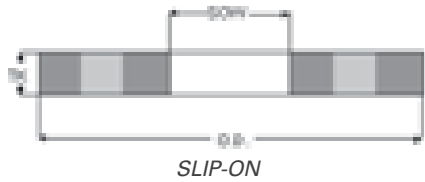

SLIP-ON



BLIND

TABLE D

SIZE	SLIP ON BORE	OUTER DIA.	THICKNESS	BOLT CIRCLE DIA.	# OF HOLES	DIA. OF HOLES
mm	SOW	OD	TK	PCD		
15	22.3	95	5	67	4	14
20	27.6	100	5	73	4	14
25	34.5	115	5	83	4	14
32	43.1	120	6	87	4	14
40	49.5	135	6	98	4	14
50	61.9	150	8	114	4	18
65	74.6	165	8	127	4	18
80	90.6	185	10	146	4	18
90	103.3	205	10	165	4	18
100	116	215	10	178	4	18
125	143.7	255	13	210	8	18
150	170.6	280	13	235	8	18
200	221.4	335	13	292	8	18
250	276.3	405	16	356	8	22
300	327.1	455	19	406	12	22
350	359.1	525	22	470	12	26
375	381	550	22	495	12	26
400	410.4	580	22	521	12	26
450	461.7	640	25	584	12	26
500	513	705	29	641	16	26
550	564.3	760	29	699	16	30
600	615.9	825	32	756	16	30
700	717.5	910	38	845	20	30
750	768.3	995	38	927	20	33
800	819.1	1060	38	984	20	36
850	869.9	1090	50	1016	20	36
900	920.7	1175	50	1092	24	36

TABLE E

SIZE	SLIP ON BORE	OUTER DIA.	THICKNESS	BOLT CIRCLE DIA.	# OF HOLES	DIA. OF HOLES
mm	SOW	OD	TK	PCD		
15	22.3	95	6	67	4	14
20	27.6	100	6	73	4	14
25	34.5	115	7	83	4	14
32	43.1	120	8	87	4	14
40	49.5	135	9	98	4	14
50	61.9	150	10	114	4	18
65	74.6	165	10	127	4	18
80	90.6	185	11	146	4	18
90	103.3	205	13	165	8	18
100	116	215	13	178	8	18
125	143.7	255	14	210	8	18
150	170.6	280	17	235	8	22
200	221.4	335	19	292	8	22
250	276.3	405	22	356	12	22
300	327.1	455	25	406	12	26
350	359.1	525	29	470	12	26
375	410.4	550	32	495	12	26
400	410.4	580	32	521	12	26
450	461.7	640	35	584	16	26
500	513	705	38	641	16	26
550	564.3	760	44	699	16	30
600	615.9	825	48	756	16	33
700	717.5	910	54	845	20	33
750	768.3	995	54	927	20	36
800	819.1	1060	54	984	20	36
850	869.9	1090	57	1016	20	36
900	920.7	1175	64	1092	24	36

TECHNICAL DATA

PLATE FLANGE DIMENSIONS

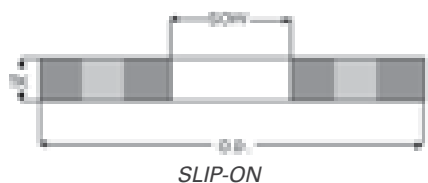

TABLE F

SIZE	SLIP ON BORE	OUTER DIA.	THICKNESS	BOLT CIRCLE DIA.	# OF HOLES	DIA. OF HOLES
mm	SOW	OD	TK	PCD		
15	22.3	95	10	67	4	14
20	27.6	100	10	73	4	14
25	34.5	120	10	87	4	18
32	43.1	135	13	98	4	18
40	49.5	140	13	105	4	18
50	61.9	165	16	127	4	18
65	74.6	185	16	146	8	18
80	90.6	205	16	165	8	18
90	103.3	215	19	178	8	18
100	116	230	19	191	8	18
125	143.7	280	22	235	8	22
150	170.6	305	22	260	12	22
200	221.4	370	25	324	12	22
250	276.3	430	29	381	12	26
300	327.1	490	32	438	16	26
350	359.1	550	35	495	16	30
375	410.4	580	38	521	16	30
400	410.4	610	41	552	20	30
450	461.7	675	44	610	20	33
500	513	735	51	673	24	33
550	564.3	785	54	724	24	33
600	615.9	850	57	781	24	36
700	717.5	935	60	857	24	36
750	768.3	1015	67	940	28	36
800	819.1	1060	68	984	28	36
850	869.9	1090	70	1016	32	36
900	920.7	1185	76	1105	32	39

TABLE H

SIZE	SLIP ON BORE	OUTER DIA.	THICKNESS	BOLT CIRCLE DIA.	# OF HOLES	DIA. OF HOLES
mm	SOW	OD	TK	PCD		
15	22.3	115	13	83	4	18
20	27.6	115	13	83	4	18
25	34.5	120	14	87	4	18
32	43.1	135	17	98	4	18
40	49.5	140	17	105	4	18
50	61.9	165	19	127	4	18
65	74.6	185	19	146	8	18
80	90.6	205	22	165	8	18
90	103.3	215	22	178	8	18
100	116	230	25	191	8	18
125	143.7	280	29	235	8	22
150	170.6	305	29	260	12	22
200	221.4	370	32	324	12	22
250	276.3	430	35	381	12	26
300	327.1	490	41	438	16	26
350	359.1	550	48	495	16	30
375	410.4	580	50	521	16	30
400	410.4	610	54	552	20	30
450	461.7	675	60	610	20	33
500	513	735	67	673	24	33
550	564.3	785	70	724	24	33
600	615.9	850	76	781	24	36



**AUSTRALIA'S LARGEST
INDEPENDENT
STAINLESS STOCKISTS**

HEAD OFFICE & COIL CENTRE

Street: 56 Business Street YATALA QLD 4207
Postal: PO Box 621 BEENLEIGH QLD 4207 AUSTRALIA

P (07) 3382 9500 | **F** (07) 3807 8150
E headoffice@midwaymetals.com.au

ALBURY

Prospero Court ALBURY NSW 2640
P (02) 6041 4000 | **F** (02) 6041 4422
E albury@midwaymetals.com.au

BRISBANE

Corner Rom & Binary Streets YATALA QLD 4207
P (07) 3287 2811 | **F** (07) 3807 2687
E brisbane@midwaymetals.com.au

MELBOURNE

33 Tatterson Road DANDENONG VIC 3175
P (03) 9791 5111 | **F** (03) 9791 5333
E melbourne@midwaymetals.com.au

NEWCASTLE

12 Sandringham Avenue THORTON NSW 2322
P (02) 4966 3800 | **F** (02) 4966 3811
E newcastle@midwaymetals.com.au

PERTH

471 Victoria Road MALAGA WA 6090
P (08) 9248 6944 | **F** (08) 9248 6955
E perth@midwaymetals.com.au

SYDNEY

24-28 Lockwood Road ERSKINE PARK NSW 2759
P (02) 9670 8900 | **F** (02) 9834 2441
E sydney@midwaymetals.com.au

TOWNSVILLE

331-335 Woolcock Street GARBUTT QLD 4814
P (07) 4728 8777 | **F** (07) 4728 8778
E townsville@midwaymetals.com.au

AUCKLAND

P +64 9 424 4194 | **F** +64 9 424 4194
E auckland@midwaymetals.com.au

VIETNAM

P +84 3 5184 8468 | **F** +84 3 5184 8456
E info@midwaymetals.com.vn

www.midwaymetals.com.au

DISCLAIMER

The technical information contained in this publication should not be relied on for specific applications without first securing competent advice. Whilst all care is taken to ensure that the information contained herein is accurate and up-to-date, Midway Metals Pty Ltd does not warrant its accuracy or completeness and does not accept liability for errors or omissions.

COPYRIGHT

All rights reserved. No part of this publication may be reproduced or distributed in any form or by any means, or stored in a database or retrieval system, without prior written permission of Midway Metals.